

Ramco Innovations

1207 Maple St. West Des Moines, IA 50265

Tel.: (800) 280-6933

Fax.: (515) 225-0063

E-mail: ramco@ramcoinnovations.com

http://www.ramcoinnovations.com

INSTRUCTION MANUAL

RI-CLAC-001 Ver. 1

Compact Line AC & AC/DC

The Compact Line is our standard series of inductive proximity sensors, a complete range of products are offered for use in most applications.

1- Model:

PS 5 - 18 GM 50 - WA - 6

Inductive Sensors:

Nominal Sensing Distance:

Sn = 2,4,5,8,10,15mm

Diameter:

M12x1, M18x1, M30x1,5

Housing Type:

-- metallic (brass) flat tube

GM - metallic (brass) threaded tube - side led

GI - metallic (brass) threaded tube - back led

GX - metallic (stainless steel) threaded tube - back led

GT - metallic (brass) threaded Tefloncoated- back led

GP - plastic threaded tube - back led

Tube Length:

60mm - M12

50mm - M18 and M30

70mm - M12 , M18 and M30 (long)

Electrical Connection:

UA - AC/DC 2 wire NO

UF - AC/DC 2 wire NC

UZA - AC/DC 2 wire NO with short circuit protection

UZF - AC/DC 2 wire NO with short circuit protection

WA - AC 2 wire NO

WF - AC 2 wire NC

Connection:

-- standard - PVC cable 2m

6 - PVC cable 6m

PU - polyurethane 2m

V1 - 3 or 4 pin male M12 connector

1.1 - Specification: 2 Wire WA and WF:

Operation Voltage 20 ~ 250Vac

AC Frequency 50 to 60Hz

Max. Output current 500mA

Inrush current (t 20ms / f 1Hz) - 4A (1A to M12)

Residual current (load not powered) <2,5mA

Minimum load current (load powered) 5mA

Output voltage drop (load powered) 5V

Indicator led

Hysteresis 5%

Repeatability < 0,01mm

EMC IEC 947-5-2 / IEC 1000-4-2, 3, 4, 5 / EN: 50082-2

Ambient temperature -25 °C ~ +70 °C

Vibration withstand f 55Hz / a 1mm

Impact resistance b 30g / t 11ms

Protection class IP67

Metallic housing Nickel plated brass

Plastic housing Rynitthermoplastic

Note: thermoplastic models do not have a grounding wire.

1.2 - AC Models:

Models WA with cable or connector	Sn mm	Φ mm	Plate mm	Mtng.	Freq. Hz
PS2-12GM60-WA	2	M12	□ 12	G	10
PS2-12GI(GP)60-WA (-V1)	2	M12	□ 12	G	10
PS4-12GM60-WA	4	M12	□ 12	O	10
PS4-12GI(GP)60-WA (-V1)	4	M12	□ 12	O	10
PS5-18GM50-WA	5	M18	□ 18	G	10
PS5-18GI(GP)50-WA (-V1)	5	M18	□ 18	G	10
PS5-18GI(GP)70-WA	5	M18	□ 18	G	10
PS8-18GM50-WA	8	M18	□ 24	O	10
PS8-18GI(GP)50-WA (-V1)	8	M18	□ 24	O	10
PS8-18GI(GP)70-WA	8	M18	□ 24	O	10
PS10-30GM50-WA	10	M30	□ 30	G	10
PS10-30GI(GP)50-WA (-V1)	10	M30	□ 30	G	10
PS10-30GI(GP)70-WA (-V1)	10	M30	□ 30	G	10
PS15-30GI50-WA	15	M30	□ 45	O	10
PS15-30GI(GP)50-WA (-V1)	15	M30	□ 45	O	10
PS15-30GI(GP)70-WA (-V1)	15	M30	□ 45	O	10

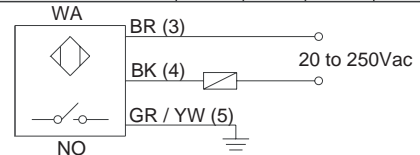

Models WF with cable and connector	Sn mm	Φ mm	Plate mm	Mtng.	Freq. Hz
PS2-12GM60-WF	2	M12	□ 12	G	10
PS2-12GI(GP)60-WF (-V1)	2	M12	□ 12	G	10
PS4-12GM60-WF	4	M12	□ 12	O	10
PS4-12GI(GP)60-WF (-V1)	4	M12	□ 12	O	10
PS5-18GM50-WF	5	M12	□ 18	G	10
PS5-18GI(GP)50-WF (-V1)	5	M12	□ 18	G	10
PS5-18GI(GP)70-WF (-V1)	5	M18	□ 18	G	10
PS8-18GM50-WF	8	M18	□ 24	O	10
PS8-18GI(GP)50-WF (-V1)	8	M18	□ 24	O	10
PS8-18GI(GP)70-WF (-V1)	8	M18	□ 24	O	10
PS10-30GM50-WF	10	M18	□ 30	G	10
PS10-30GI(GP)50-WF (-V1)	10	M18	□ 30	G	10
PS10-30GI(GP)70-WF (-V1)	10	M18	□ 30	G	10
PS15-30GM50-WF	15	M18	□ 45	O	10
PS15-30GI(GP)50-WF (-V1)	15	M18	□ 45	O	10
PS15-30GI(GP)70-WF (-V1)	15	M18	□ 45	O	10

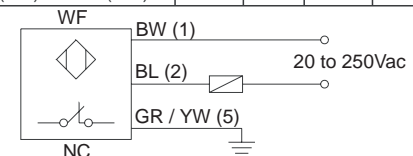

Note: If the supplied sensor isn't listed in the tables above, but uses the same type of output with the codes "E, E2, A, A2, N, N4 and N5" these instructions are applicable EG: PS2-12GX60-WA (special model with stainless steel tube).

G = Flush Mounting O = Non Flush Mounting

1.3 - AC and AC/DC Models:

Models UA and UF with cable or connector	Sn mm	Φ mm	Plate mm	Mtng.	Freq. Hz
PS5-18GI70-UA (-V1)	5	M18	□ 18	O	25
PS5-18GI70-UF (-V1)	5	M18	□ 18	O	25
PS8-18GI70-UA (-V1)	8	M18	□ 24	G	25
PS8-18GI70-UF (-V1)	8	M18	□ 24	G	25
PS10-30GI70-UA (-V1)	10	M30	□ 30	O	25
PS10-30GI70-UF (-V1)	10	M30	□ 30	O	25
PS15-30GI70-UA (-V1)	15	M30	□ 45	G	25
PS15-30GI70-UF (-V1)	15	M30	□ 45	G	25

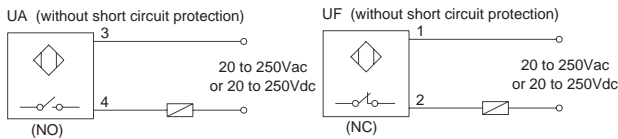

Models UZA and UZF with cable or connector	Sn mm	Φ mm	Plate mm	Mtng.	Freq. Hz
PS10-30GI70-UZA (-V1)	10	M30	□ 30	O	25
PS10-30GI70-UZF (-V1)	10	M30	□ 30	O	25
PS15-30GI70-UZA (-V1)	15	M30	□ 45	G	25
PS15-30GI70-UZF (-V1)	15	M30	□ 45	G	25

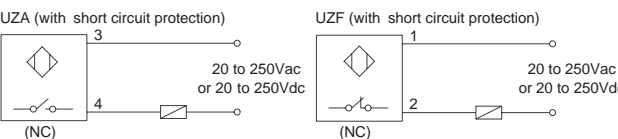

1.4 - AC/DC 2 Wire U(Z)A and U(Z)F:

Operating voltage DC 20 to 250Vdc
 Max. ripple DC 5%
 Operating voltage AC 20 to 250Vac
 Frequency AC 45 to 65Hz
 Max. Output current 300mA (dc or ac)
 Inrush current (t 20ms / f 1Hz) - 4A (dc or ac)
 Residual current (load not powered) <2,5mA (dc or ac)
 Min. load current (load powered) 5mA (dc or ac)
 Output voltage drop (load powered) 5V (dc or ac)
 Short circuit and overload protection UZ models only
 Indicator led
 Hysteresis 5%
 Repeatability < 0,01mm
 EMC IEC 947-5-2 / IEC 1000-4-2, 3, 4, 5 / EN: 50082-2
 Operating temperature -25 °C ~ +70 °C
 Vibration withstand f 55Hz / a 1mm
 Impact resistance b 30g / t 11ms
 Protection class IP67
 Plastic housing Rynite thermoplastic

Connection:

Connector V1:

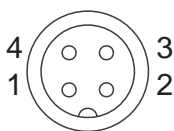

Cable:

BW - brown (1)
 BL - blue (3)
 BK - black (4)
 WH - white(2)

2 - Inductive Proximity Sensors:

An inductive proximity sensor is able to detect the presence of metal parts, components, machine elements, etc. without directly contacting the part. It can easily replace traditional mechanical switches. This detection does not require physical contact between the target and the sensor, and since there is no mechanical stress applied, the overall life of the sensor is considerably longer than that of a mechanical device.

2.1 - Operating Principle:

The principle of operation is based on high frequency magnetic field generation, the field is projected from a coil mounted in the face of the sensor. This magnetic field is the sensing area. When a metallic object (ferrous or non ferrous) is introduced into the projected field, eddy currents are induced in the surface of the target and absorb the energy from the field. This change in the field will be detected by the detection circuit and the output is activated.

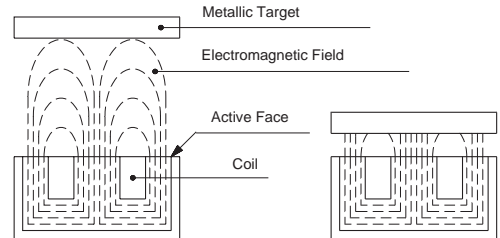

2.2 - Sensing Face:

The surface of the sensor where the magnetic field is projected.

2.3 - Sensing Distance:

The distance at which the target when approaching the sensing face will cause the output of the sensor to change state.

2.4 - Nominal Sensing Distance (Sn):

This is the theoretical sensing distance, when using a standard test plate as a target. It does not take into account the variations caused by manufacturing tolerances, operating temperature changes, supply voltage variations, etc. This is the distance used in the proximity sensor specification. Also since a standard test plate is used, the nominal sensing distance specifies the maximum distance at which the sensor can operate.

$$L=D (3xSn < D) \text{ or}$$

$$L=3xSn (3xSn > D)$$

D - diameter of the area where the magnetic field is projected.

Sn - nominal sensing distance

2.5 - Operational Sensing Distance:

The distance that the sensor will operate reliably, regardless of temperature changes, power supply fluctuations, etc.

$$0 < Sa < 0.81 = Sn$$

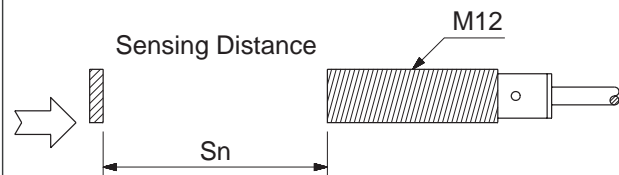

2.6 - Standard Test Plate:

The standard target that is used to calibrate the nominal sensing distance during the manufacturing process.

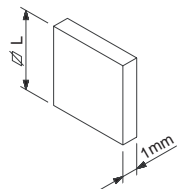

Note: If the supplied sensor isn't listed in the tables above, but uses the same type of output with the codes "E, E2, A, A2, N, N4 and N5" these instructions are applicable EG: PS2-12GX60-WA (special model with stainless steel tube).

G = Flush Mounting O = Non Flush Mounting

Electrical Configuration AC & AC/DC

RI-CLAC-001 Ver.1

2.7 - Target Material:

The sensing distance is specified with mild steel and will vary with other materials. When used in an application with a metal target other than steel, the actual distance may be reduced.

To calculate the actual sensing distance multiply the rated sensing distance by the factor shown in the table on the right.

Material	Factor
iron or steel	1,0
nickel chromium	0,9
stainless steel	0,85
brass	0,5
aluminum	0,4

2.8 - Hysteresis:

The difference between the activation point (D_a - when the target is approaching the sensor) and the deactivation point (D_d - when the target is moving away from the sensor) is known as Hysteresis. This difference assures that the output will remain constant if there is a slight vibration or movement of the target.

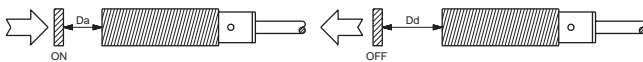

3 - AC Switching Voltage:

The AC version sensors (models WA and WF), will operate within the range of 20 to 250 VAC, at either 50 or 60 Hz.

Note: AC sensors cannot be used in DC control circuits, this could result in damage to the sensor.

3.1 - AC/DC Switching Voltage:

The AC/DC model sensors (UA, UF, UZA, UZF) can be used with both AC and or DC control circuits, in the range of 20 to 250 V (AC power 50 or 60 Hz) This type of sensor was designed specifically for higher voltage DC circuits (110 VDC), for low level automation circuits we recommend that you use a standard DC model sensor: N4, N5 (2 wire), E, A (NPN 3 wire), or E2, A2 (PNP 3 wire).

3.1.1 - Shielded:

A shielded sensor can be mounted flush in a metal surface. The magnetic field is only projected out from the face of the sensor. Any metal around the sensor body will not affect the operation of the sensor.

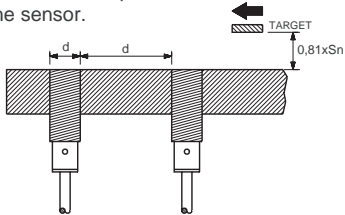

3.1.2 - Non Shielded:

A non shielded sensor cannot be mounted flush in a metal surface. The magnetic field is projected around the entire end of the sensor. This results in a sensing distance that is longer than a sensor of the same size that is shielded.

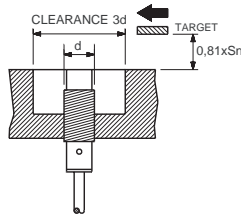

3.2 - Residual Voltage Drop:

This is the voltage drop that occurs in the sensor when the load is activated, this is important with high impedance loads (electronic). Special care must be taken when used with low voltage electronic inputs such as a PLC input. Please verify the compatibility of the sensor and the controller.

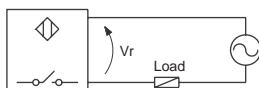

3.3 - Output Switching Current:

This is the maximum current that can be switched without damaging the sensor.

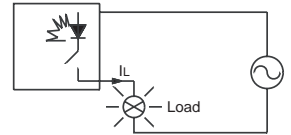

AC model sensors are rated at 500mA, while the AC/DC sensors are rated at 300mA.

3.4 - Short Circuit and Overload Protection:

The AC model sensors WA and WF, as well as the AC/DC models UA and UF DO NOT HAVE protection against short circuits or overload conditions and will be permanently damaged if either should occur. Do not connect to loads that require more current than the maximum rating. The AC/DC models UZA and UZF do have internal short circuit and overload protection. This will prevent damage to the sensor if a short circuit or overload occurs.

3.5 - Inrush Current:

The maximum allowable peak current that a sensor can tolerate without damage. This usually occurs with inductive loads such as solenoids, motors, etc. It is specified as shorter than 20 ms in duration and a working frequency that is less than 1 Hz. Typically the values will be in the range of 2A to 4A, depending upon the model of sensor.

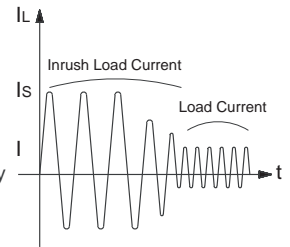

3.6 - Residual Current:

This is the current that flows through the load when the output is not activated, this is required to operate the sensor circuit. In a two-wire sensor, this value is less than 5mA and with a three-wire sensor it is almost zero.

Caution: in applications with old programmable controllers and two-wire sensors, verify that the residual current does not activate the I/O card, it is possible that the slight amount of current flow could be interpreted as a logic level of 1.

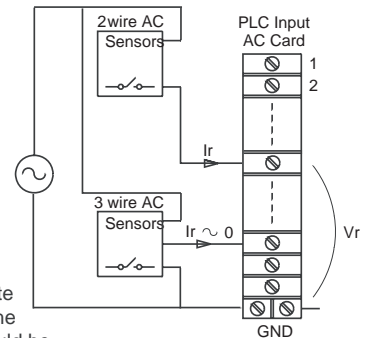

3.7 - Minimum Load Current:

A two wire sensor requires a small amount of current flow to keep the sensor operating when the load is not activated. Also when the load is activated at least 5 mA is needed for proper operation of the sensor.

3.8 - Protection:

There is a high voltage peak protection stage incorporated into the sensor, this provides a level of protection for the sensor when noise is induced into the power supply from inductive loads or high voltage power leads. This protection is only effective for normal operation and if the sensor is exposed to high voltage spikes that exceed the specified rating it can be permanently damaged.

4 - General Precautions:

Please see below, there are a few general precautions that the user should follow during the setup and operation of the proximity sensor.

A lack of attention to these details may result in poor performance or permanent damage to the sensor, with the implied loss of warranty.

If there are any questions concerning the appropriate sensor to use for your application or for more technical information please call the number listed.

4.1 - Connecting Cable:

Avoid applying excessive stress or strain on the sensor cable. This can cause damage to the cable and premature failure of the sensor.

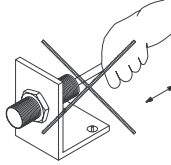

4.2 - Vibration:

The sensor body is encapsulated with resin, making it applicable for use on moving equipment. The cable should be securely fastened at both ends. Do not allow the cable to flex where it enters the sensor body, this can cause damage to the cable and premature failure of the sensor.

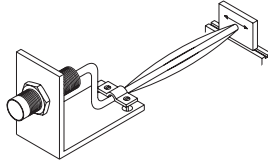

4.3 - Mounting Bracket:

The sensor should not be mounted in a location where it will be subjected to damage due to impact with other parts or pieces of equipment. Also do not use the sensor as a support. If impacts cannot be avoided use a protective bracket around the sensor body.

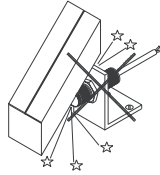

4.4 - Moving Parts:

When performing the initial setup of the sensor, please verify that there is sufficient clearance between the sensor and the target. The sensor should not be damaged by an impact with the actuator.

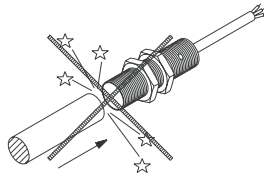

4.5 - Maximum Torque:

Do not exceed the recommended tightening torque when mounting the sensor.

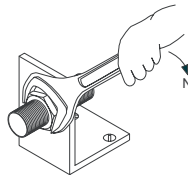

4.6 - Chemical Resistance:

When used in areas where the sensor may come in contact with hazardous chemicals, ensure that the sensor will not react with the chemicals. If necessary please contact us for assistance in selecting an appropriate sensor for your application.

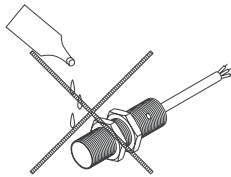

4.7 - Environmental Conditions:

Avoid using the sensor in locations where the ambient temperature exceeds the specified operating temperature.

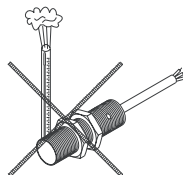

4.8 - Cabling:

Do not run the sensor cable next to high-voltage lines or motor leads, also do not run together in the same conduit or raceway.

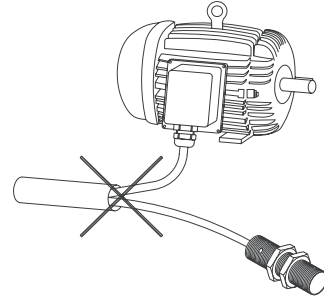

Note: Even though there are filters in the sensors to make them tolerant to electrical noise, the induced voltage from large inductive loads such as motors, electric brakes, solenoids, contactors, etc. can damage the sensor.

4.9 - High Current Loads:

Using the sensor to activate high current inductive loads, can cause the output section of non short circuit protected sensors to be permanently damaged. This type of load also generates high voltage spikes back into the power supply which may shorten the life of the sensor.

Inductive loads, such as contactors, relays, solenoids, etc. should be checked prior to use. The switching current required for operation or the inrush current could damage the sensor.

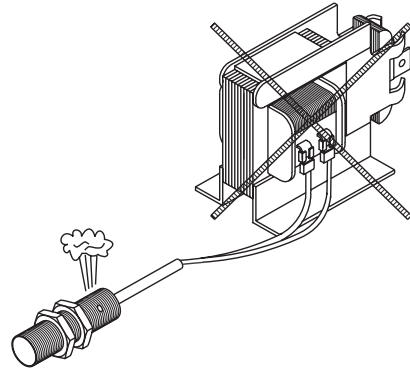

4.10 - Incandescent Lights:

Incandescent lights must not be used with sensors that do not have short circuit protection in the output, the current required when the filament is cold may damage the sensor.

