

CX-30 SERIES

Amplifier Built-in Cost-effective & Compact Photoelectric Sensor

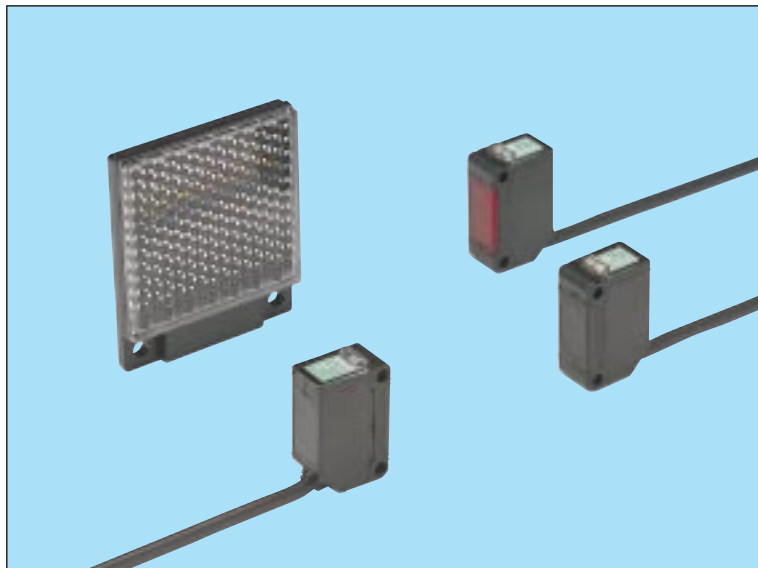

Basic Functions and Ease-of-use at a Low Price



FX-D1/A1/M1

FX-13

FX-11A

Fiber Sensors

FZ-10

CX-20

CX-30

CX-RV/M5/D100/ND300R

EX-10

EX-20

Amplifier Built-in Type

Compact Size

It is mountable in a tight space since the depth is only 20mm.

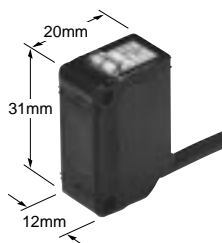

Insusceptible to High-frequency Fluorescent Light

Not affected by high-frequency fluorescent light even if it is similar to the sensor beam.

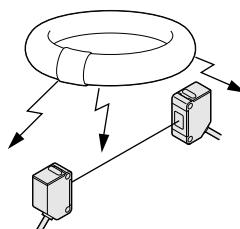

Cost-effective

It features basic functions and ease-of-use while maintaining a low price.

CX-31 (Thru-beam type)

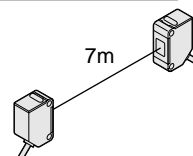

CX-39 (Retroreflective type sensor with polarizing filters)

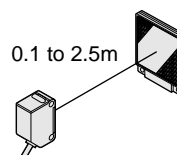

Two Sensors Mountable Together

The retroreflective type sensor with polarizing filters (CX-39A or CX-39B) incorporates an automatic interference prevention function. Hence, two sensors can be mounted close together.

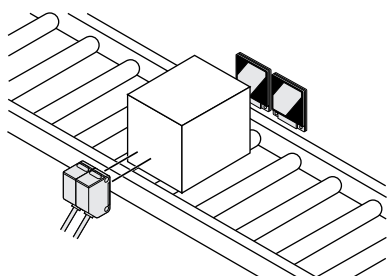

Waterproof

The sensor can be hosed down because of its IP67 construction and the non-corrosive stainless steel mounting bracket.

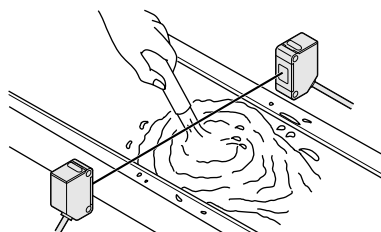

Note: However, take care that if it is exposed to water splashes during operation, it may detect a water drop itself.

Versatile Mounting

Select the bracket suitable for your installation from the range of optional mounting brackets.

APPLICATIONS

Detecting contents of paper pouch

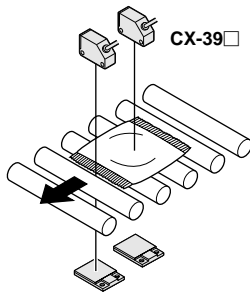

Detecting shiny home appliances

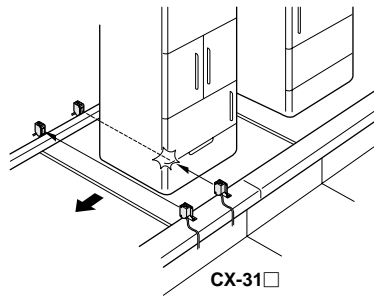

Detecting trays on washing line

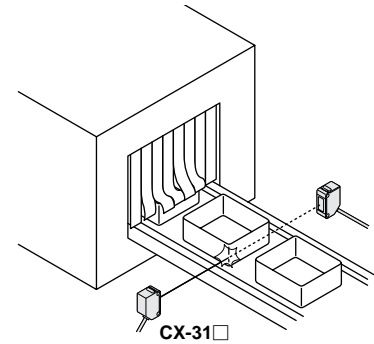

ORDER GUIDE

Type		Appearance	Sensing range	Model No.	Emitting element
Thru-beam	Light-ON		7m	CX-31A	Infrared LED
	Dark-ON			CX-31B	
Retroreflective with polarizing filters	Light-ON		0.1 to 2.5m (Note 1)	CX-39A	Red LED
	Dark-ON			CX-39B	

NOTE: Mounting bracket is not supplied with the sensor. Please select from the range of optional sensor mounting brackets (five types).

Note 1: The sensing range of the retroreflective type sensor is specified for the RF-230 reflector. Further, the sensing range is the possible setting range for the reflector. The sensor can detect an object less than 0.1m away.

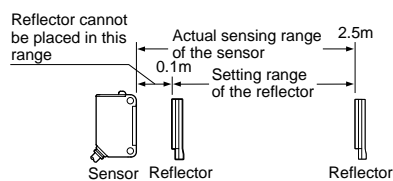

Package without reflector

CX-39A and CX-39B are available without the reflector RF-230. When ordering this type, add suffix '-Y' to the model No. Model No.: CX-39A-Y, CX-39B-Y.

FX-D1/A1/M1

FX-13

Fiber Sensors
FX-11A

FZ-10

CX-20

Amplifier Built-in Type
CX-30

CX-R/M5/D100/ND300R

EX-10

EX-20

OPTIONS

Designation	Model No.	Description	
Round slit mask (For thru-beam type sensor only)	OS-CX-05 (Slit size ϕ 0.5mm)	Slit on one side	• Sensing range: 300mm • Min. sensing object: ϕ 12mm
		Slit on both sides	• Sensing range: 15mm • Min. sensing object: ϕ 0.5mm
	OS-CX-1 (Slit size ϕ 1mm)	Slit on one side	• Sensing range: 650mm • Min. sensing object: ϕ 12mm
		Slit on both sides	• Sensing range: 70mm • Min. sensing object: ϕ 1mm
	OS-CX-2 (Slit size ϕ 2mm)	Slit on one side	• Sensing range: 1.4m • Min. sensing object: ϕ 12mm
		Slit on both sides	• Sensing range: 300mm • Min. sensing object: ϕ 2mm
Rectangular slit mask (For thru-beam type sensor only)	OS-CX-05 \times 6 (Slit size 0.5 \times 6mm)	Slit on one side	• Sensing range: 1.4m • Min. sensing object: ϕ 12mm
		Slit on both sides	• Sensing range: 300mm • Min. sensing object: 0.5 \times 6mm
	OS-CX-1 \times 6 (Slit size 1 \times 6mm)	Slit on one side	• Sensing range: 2m • Min. sensing object: ϕ 12mm
		Slit on both sides	• Sensing range: 700mm • Min. sensing object: 1 \times 6mm
	OS-CX-2 \times 6 (Slit size 2 \times 6mm)	Slit on one side	• Sensing range: 3.5m • Min. sensing object: ϕ 12mm
		Slit on both sides	• Sensing range: 1.4m • Min. sensing object: 2 \times 6mm
Reflector (For retro-reflective type sensor only)	RF-210	• Sensing range: 0.1 to 0.8m • Min. sensing object: ϕ 30mm	
	RF-220	• Sensing range: 0.1 to 1.2m • Min. sensing object: ϕ 35mm	
Reflector mounting bracket	MS-RF21-1	Protective mounting bracket for RF-210 It protects the reflector from damage and maintains alignment.	
	MS-RF22	For RF-220	
	MS-RF23	For RF-230	
Reflective tape	RF-11	• Ambient temperature: - 25 to + 50°C	• Sensing range: 0.1 to 0.4m • Min. sensing object: ϕ 30mm
		• Ambient humidity: 35 to 85% RH	
	RF-12	Notes: i) Keep the tape free from stress. If it is pressed too much, the capability may deteriorate. ii) Do not cut the tape. It will deteriorate the sensing performance.	• Sensing range: 0.1 to 0.6m • Min. sensing object: ϕ 30mm

Round slit mask

Fitted on the front face of the sensor with one-touch.

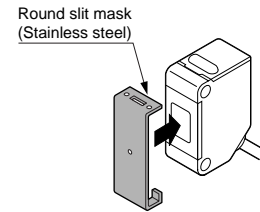
**Rectangular slit mask**

Fitted on the front face of the sensor with one-touch.

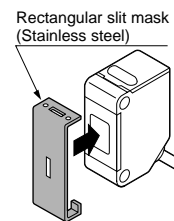
**Reflector**

• RF-210

• RF-220

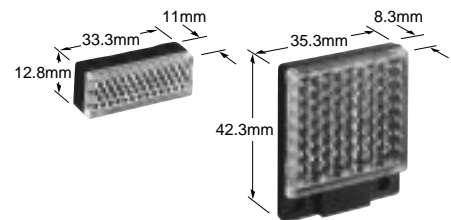
**Reflective tape**

• RF-11

• RF-12

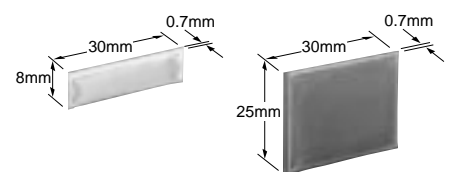
**Reflector mounting bracket**

• MS-RF23

• MS-RF22

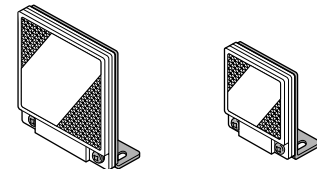

Two M4 (length 10mm) screws with washers are attached.

Two M3 (length 8mm) screws with washers are attached.

• MS-RF21-1

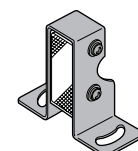

Two M3 (length 12mm) screws with washers are attached.

OPTIONS

Designation	Model No.	Description
Sensor mounting bracket	MS-CX2-1	Foot angled mounting bracket It can also be used for mounting RF-210 . (The thru-beam type sensor needs two brackets.)
	MS-CX2-2	Foot biangled mounting bracket Flat mounting saves height. It can also be used for mounting RF-210 . (The thru-beam type sensor needs two brackets.)
	MS-CX2-4	Protective mounting bracket It protects the sensor from damage and maintains alignment. (The thru-beam type sensor needs two brackets.)
	MS-CX2-5	Back biangled mounting bracket Suitable for sensing from bottom of conveyors, etc. (The thru-beam type sensor needs two brackets.)
	MS-CX-3	Back angled mounting bracket (The thru-beam type sensor needs two brackets.)
Universal sensor mounting stand (Note 1)	MS-AJ	Basic assembly
	MS-AJ-A	Lateral arm assembly
	MS-AJ-M	Assembly for reflector
Sensor checker (Note 2)	CHX-SC2	It is useful for beam alignment of thru-beam type sensors. The optimum receiver position is given by indicators, as well as, an audio signal.

Notes: 1) Refer to P.310~ for details of the universal sensor mounting stand.
2) Refer to P.378~ for details of the sensor checker **CHX-SC2**.

Sensor mounting bracket

• MS-CX2-1

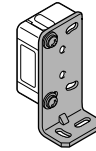

Two M3 (length 12mm) screws with washers are attached.

• MS-CX2-2

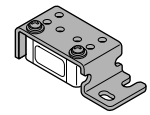

Two M3 (length 12mm) screws with washers are attached.

• MS-CX2-4

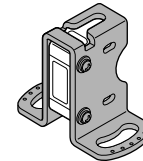

Two M3 (length 14mm) screws with washers are attached.

• MS-CX2-5

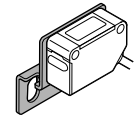

Two M3 (length 12mm) screws with washers are attached.

• MS-CX-3

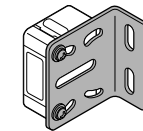

Two M3 (length 12mm) screws with washers are attached.

Universal sensor mounting stand

• MS-AJ

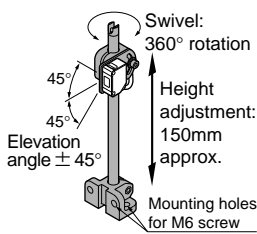

• MS-AJ-A

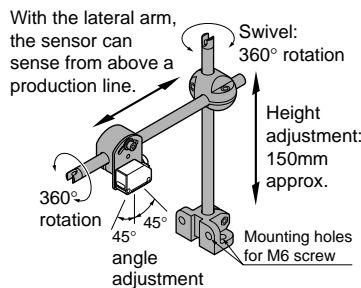

• MS-AJ-M

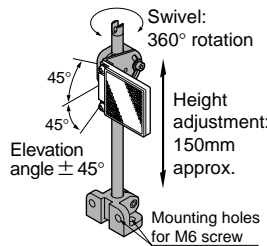

Sensor checker

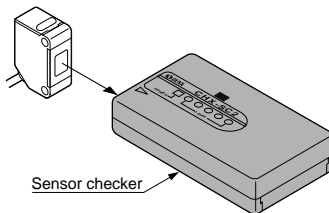

FX-D1/A1/M1

FX-13

FX-11A

FZ-10

CX-20

CX-30

Amplifier Built-in Type
CX-R/M5/D10/ND300R

EX-10

EX-20

SPECIFICATIONS

Item	Type	Thru-beam		Retroreflective with polarizing filters	
	Model No.	CX-31A	CX-31B	CX-39A	CX-39B
Sensing range		7m		0.1 to 2.5m (Note 1)	
Sensing object		φ12mm or more opaque object (Note 2)		φ50mm or more opaque, translucent or specular object (Note 1)	
Repeatability (perpendicular to sensing axis)		0.5mm or less			
Supply voltage		12 to 24V DC ± 10% Ripple P-P 10% or less			
Current consumption		Emitter: 35mA or less, Receiver: 25mA or less		30mA or less	
Output		NPN open-collector transistor			
		<ul style="list-style-type: none"> • Maximum sink current: 100mA • Applied voltage: 30V DC or less (between output and 0V) • Residual voltage: 1.5V or less (at 100mA sink current) 0.4V or less (at 16mA sink current) 			
	Utilization category	DC-12 or DC-13			
	Output operation	Light-ON	Dark-ON	Light-ON	Dark-ON
Short-circuit protection	Incorporated				
Response time		1ms or less			
Operation indicator		Red LED (lights up when the output is ON)			
Stability indicator		Green LED (lights up under stable light received condition or stable dark condition)			
Power indicator		Red LED (lights up when the power is ON)		_____	
Automatic interference prevention function		_____		Two units of sensors can be mounted closely.	
Environmental resistance	Pollution degree	3 (Industrial environment)			
	Protection	IP67 (IEC)			
	Ambient temperature	- 25 to + 55°C (No dew condensation or icing allowed), Storage: - 30 to + 70°C			
	Ambient humidity	35 to 85% RH, Storage: 35 to 85% RH			
	Ambient illuminance	Sunlight: 10,000 lx at the light-receiving face, Incandescent light: 3,000 lx at the light-receiving face			
	EMC	Emission: EN50081-2, Immunity: EN50082-2			
	Voltage withstandability	1,000V AC for one min. between all supply terminals connected together and enclosure			
	Insulation resistance	20MΩ, or more, with 250V DC megger between all supply terminals connected together and enclosure			
Vibration resistance	10 to 500Hz frequency, 1.5mm amplitude (10G max.) in X, Y and Z directions for two hours each				
Shock resistance	500m/s ² acceleration (50G approx.) in X, Y and Z directions for three times each				
Emitting element		Infrared LED (modulated)		Red LED (modulated)	
Material		Enclosure: Polycarbonate, Lens: Polycarbonate, Indicator cover: Polycarbonate, Front cover: Polycarbonate (retroreflective type: Acrylic)			
Cable		0.2mm ² 3-core (thru-beam type emitter: 2-core) oil resistant cabtyre cable, 1m long			
Cable extension		Extension up to total 100m is possible with 0.3mm ² , or more, cable (thru-beam type: both emitter and receiver).			
Weight		Emitter: 23g approx., Receiver: 25g approx.		25g approx.	
Accessory		_____ RF-230 (Reflector): 1No.			

Notes: 1) The sensing range and the sensing object of the retroreflective type sensor are specified for the **RF-230** reflector. Further, the sensing range is the possible setting range for the reflector. The sensor can detect an object less than 0.1m away.
2) If slit masks (optional) are fitted, an object of φ0.5mm (using round slit masks) can be detected.

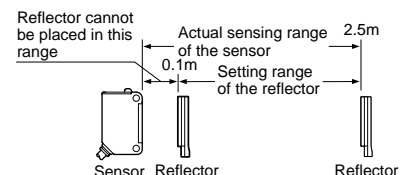

I/O CIRCUIT AND WIRING DIAGRAMS

I/O circuit diagram

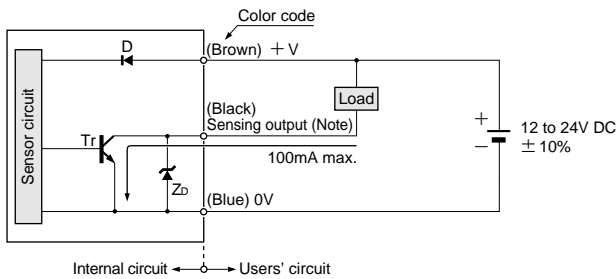

Note: The emitter of the thru-beam type sensor does not incorporate the sensing output.

Wiring diagram

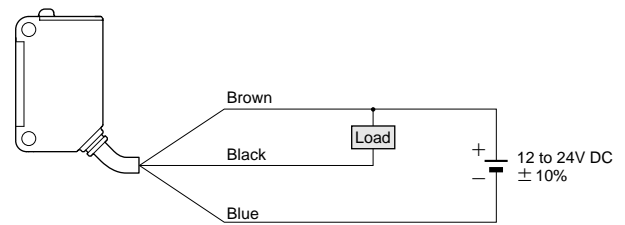

Symbols ... D: Reverse supply polarity protection diode
ZD: Surge absorption zener diode
Tr: NPN output transistor

SENSING CHARACTERISTICS (TYPICAL)

**CX-31A
CX-31B**

Thru-beam type

Parallel deviation

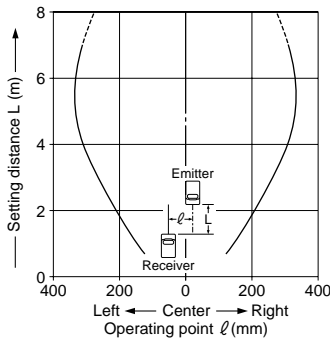

Angular deviation

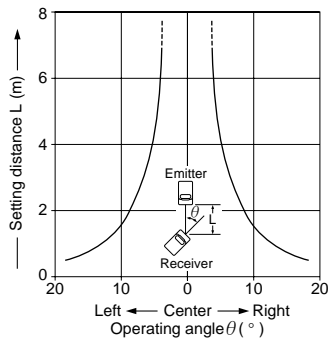

Parallel deviation with round slit masks (phi 0.5mm)

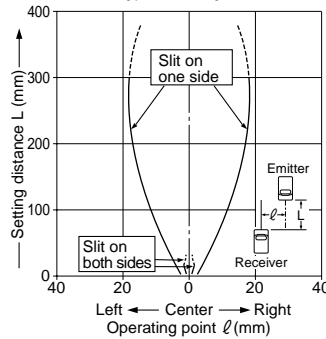

Parallel deviation with round slit masks (phi 1mm)

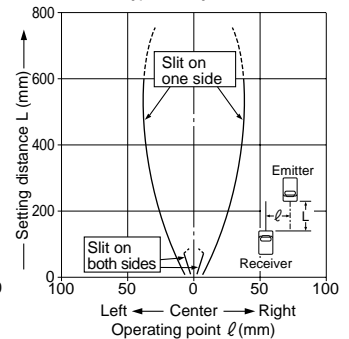

Parallel deviation with round slit masks (phi 2mm)

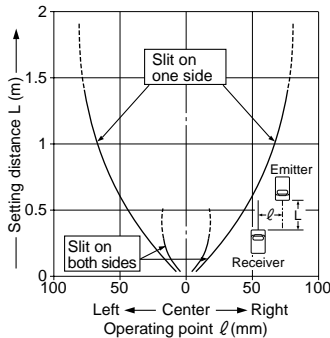

Parallel deviation with rectangular slit masks (0.5 x 6mm)

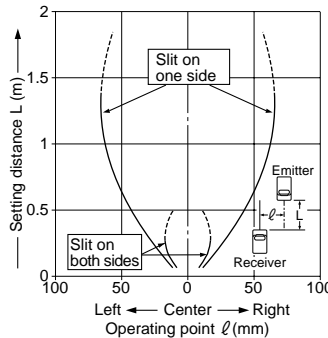

Parallel deviation with rectangular slit masks (1 x 6mm)

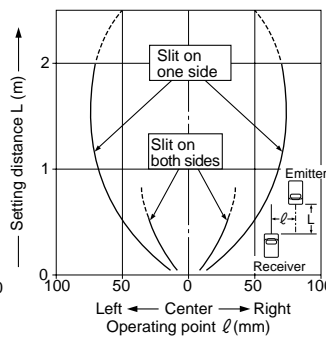

Parallel deviation with rectangular slit masks (2 x 6mm)

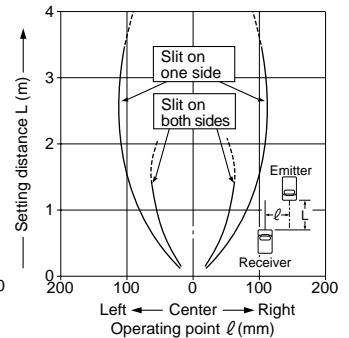

**CX-39A
CX-39B**

Retroreflective type

Parallel deviation

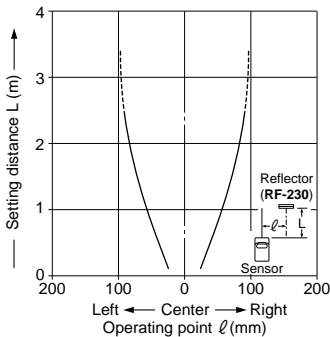

Angular deviation

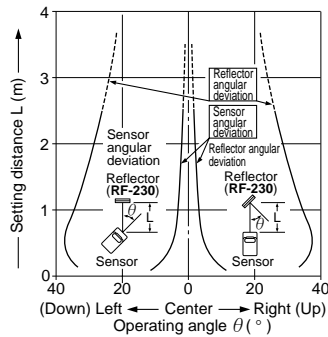

All models

Correlation between setting distance and excess gain

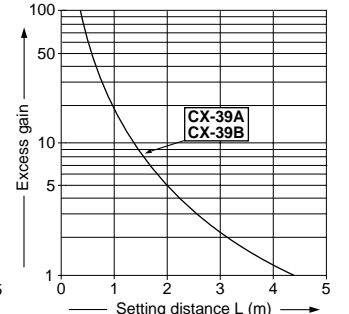
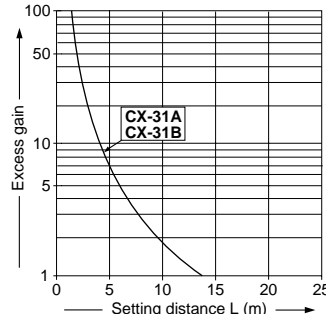

FX-D1/A1/M1

FX-13

Fiber Sensors

FX-11A

FZ-10

CX-20

Amplifier Built-in Type

CX-30

CX-R/M5/D10/ND30/R

EX-10

EX-20

CX-30

PRECAUTIONS FOR PROPER USE

Refer to P.820~ for general precautions.

 This product is not a safety sensor. Its use is not intended or designed to protect life and prevent body injury or property damage from dangerous parts of machinery. It is a normal object detection sensor.

Mounting

- The tightening torque should be 0.5N·m or less.

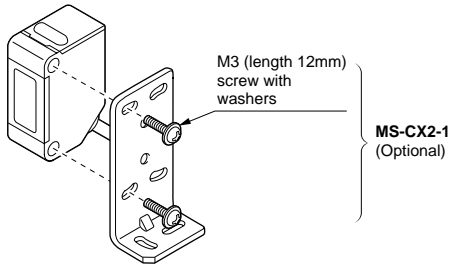

Retroreflective type sensor with polarizing filters

- If a shiny object is covered or wrapped with a transparent film, such as those described below, the retroreflective type sensor with polarizing filters may not be able to detect it.

In that case, follow the steps given below.

Example of sensing objects

- Can wrapped by clear film
- Aluminum sheet covered by plastic film
- Gold or silver color (glossy) label or wrapping paper

Steps

- Tilt the sensor with respect to the sensing object while fitting.
- Reduce the sensitivity.
- Increase the distance between the sensor and the sensing object.

Others

- Do not use during the initial transient time (50ms) after the power supply is switched on.

DIMENSIONS (Unit: mm)

CX-31A CX-31B
CX-39A CX-39B Sensor

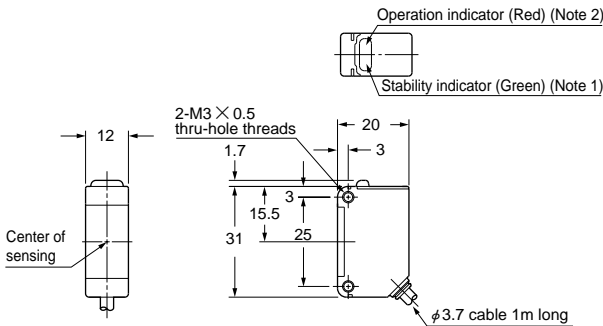

Notes: 1) Not incorporated on the emitter of the thru-beam type sensor.
2) It is the power indicator (red) on the emitter of the thru-beam type sensor.

RF-230 Reflector (Accessory for the retroreflective type sensor)

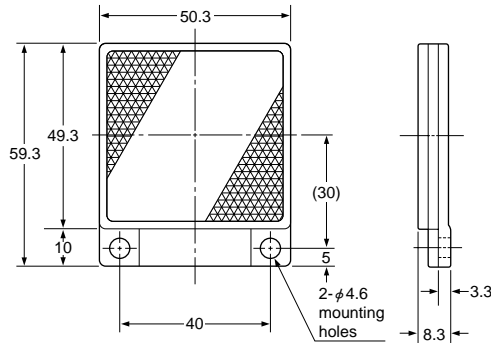

Material: Acrylic (Reflector)
ABS (Base)

RF-220 Reflector (Optional)

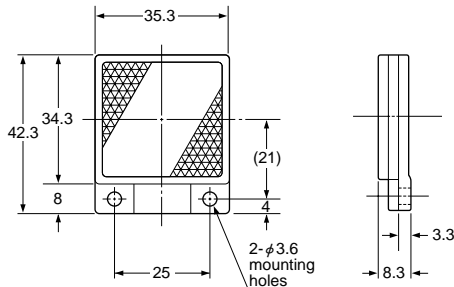

Material: Acrylic (Reflector)
ABS (Base)

RF-210 Reflector (Optional)

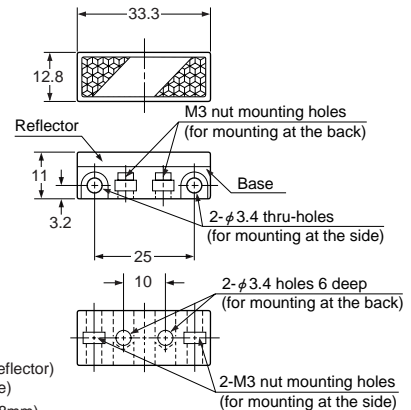

Material: Acrylic (Reflector)
ABS (Base)

Two M3 (length 8mm) screws with washers and two nuts are attached.

DIMENSIONS (Unit: mm)

RF-11 Reflective tape (Optional)

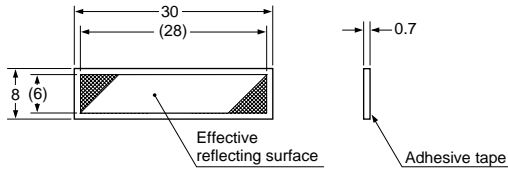

Material: Acrylic

RF-12 Reflective tape (Optional)

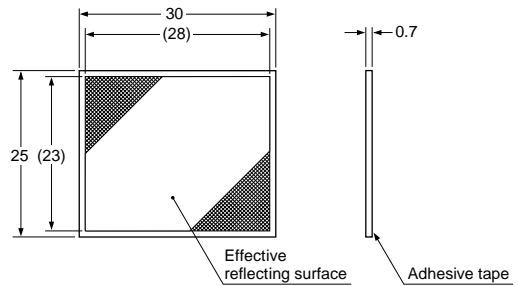

Material: Acrylic

MS-CX2-1 Sensor mounting bracket (Optional)

Assembly dimensions

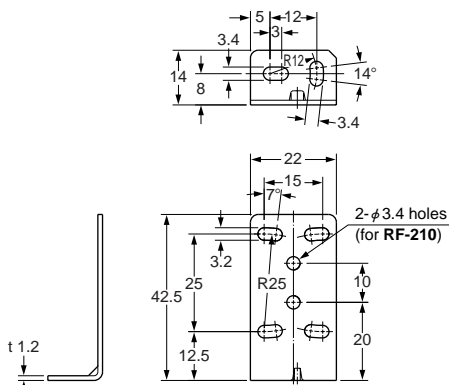

Material: Stainless steel (SUS304)
Two M3 (length 12mm) screws with washers are attached.

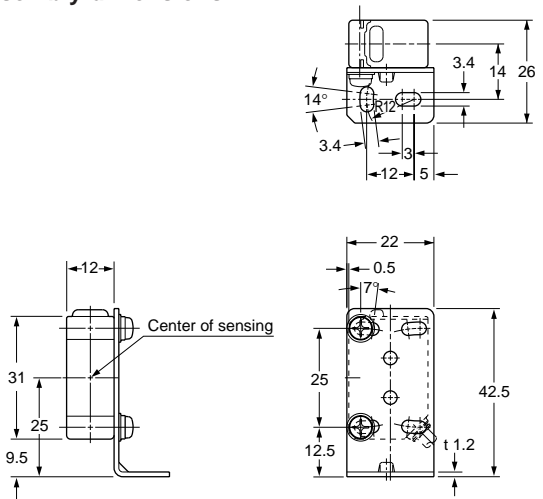

MS-CX2-2 Sensor mounting bracket (Optional)

Assembly dimensions

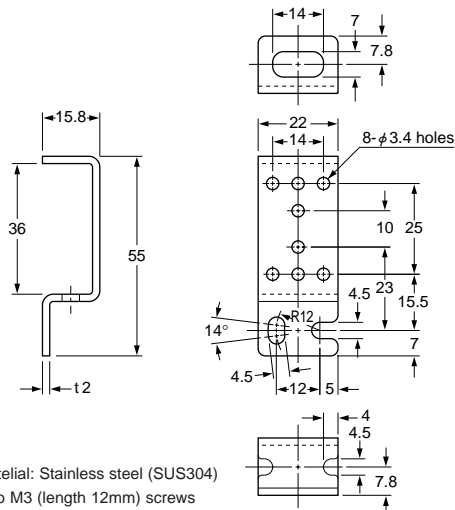

Material: Stainless steel (SUS304)
Two M3 (length 12mm) screws with washers are attached.

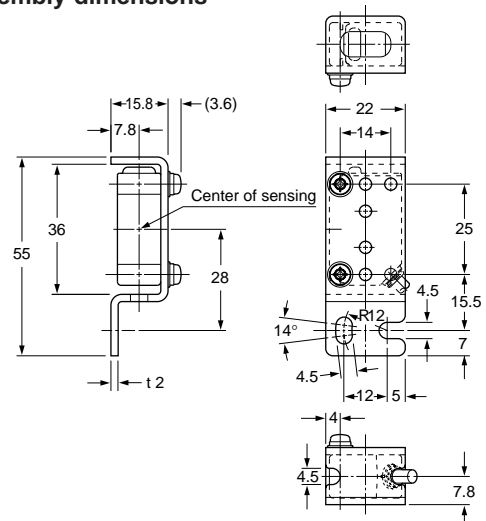

FX-D1/A1/M1

FX-13

FX-11A

FZ-10

CX-20

CX-30

CX-R/M5/D100/ND300R

EX-10

EX-20

Amplifier Built-in Type

CX-30

DIMENSIONS (Unit: mm)

MS-CX2-4 Sensor mounting bracket (Optional)

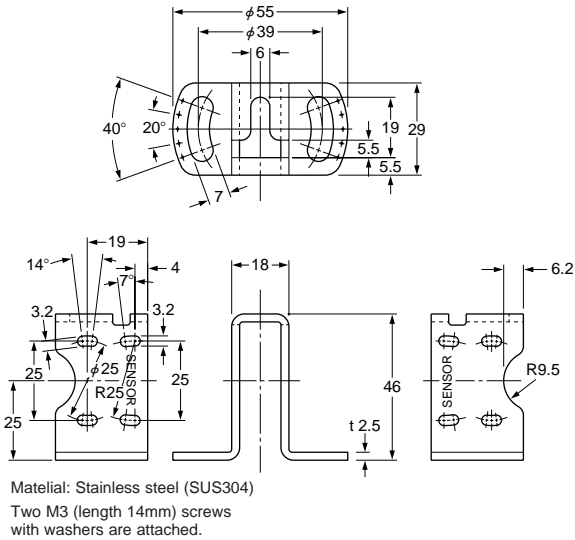

Assembly dimensions

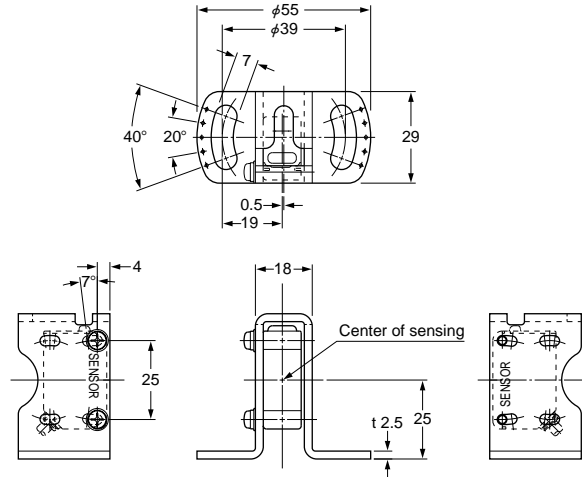

MS-CX2-5 Sensor mounting bracket (Optional)

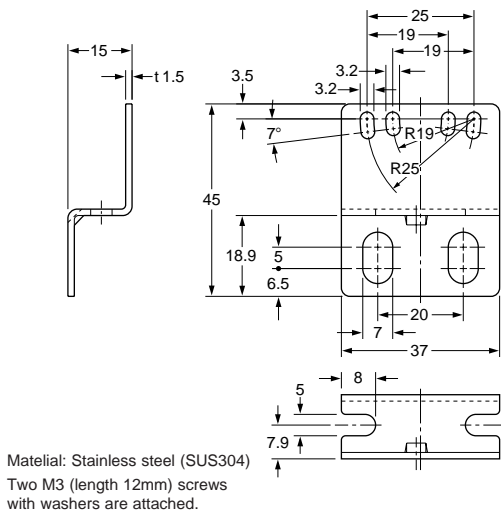

Assembly dimensions

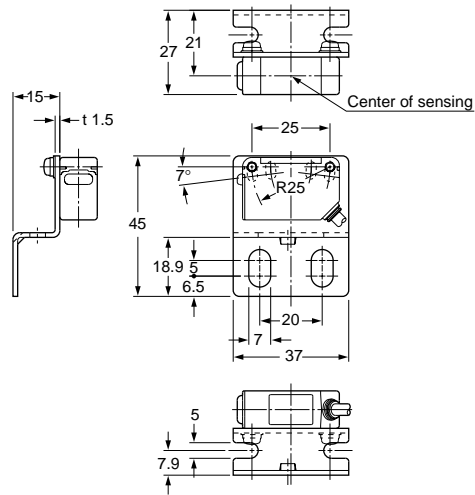

MS-CX-3 Sensor mounting bracket (Optional)

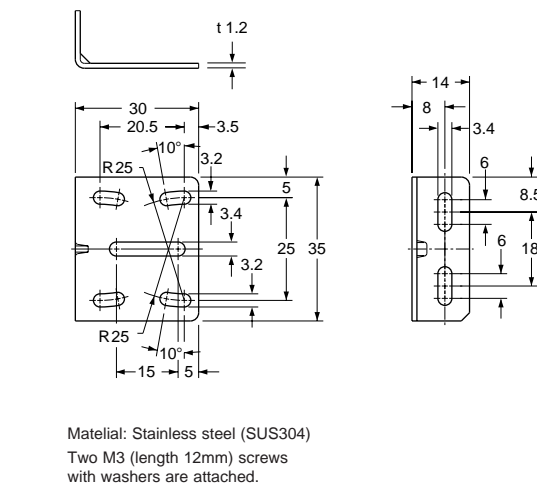

Assembly dimensions

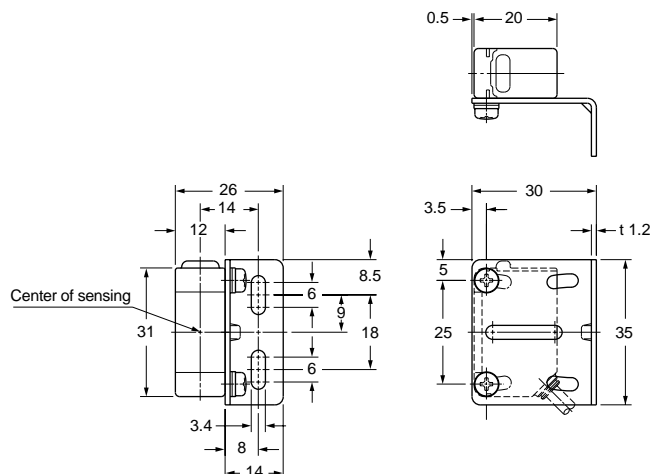

DIMENSIONS (Unit: mm)

MS-RF21-1 Reflector mounting bracket for RF-210 (Optional)

Assembly dimensions

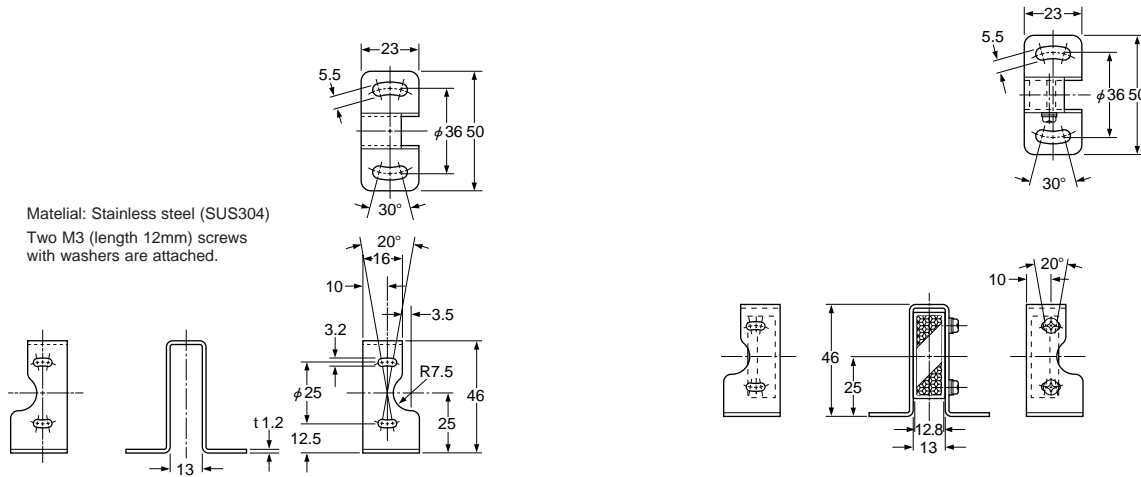

MS-RF22 Reflector mounting bracket for RF-220 (Optional)

Assembly dimensions

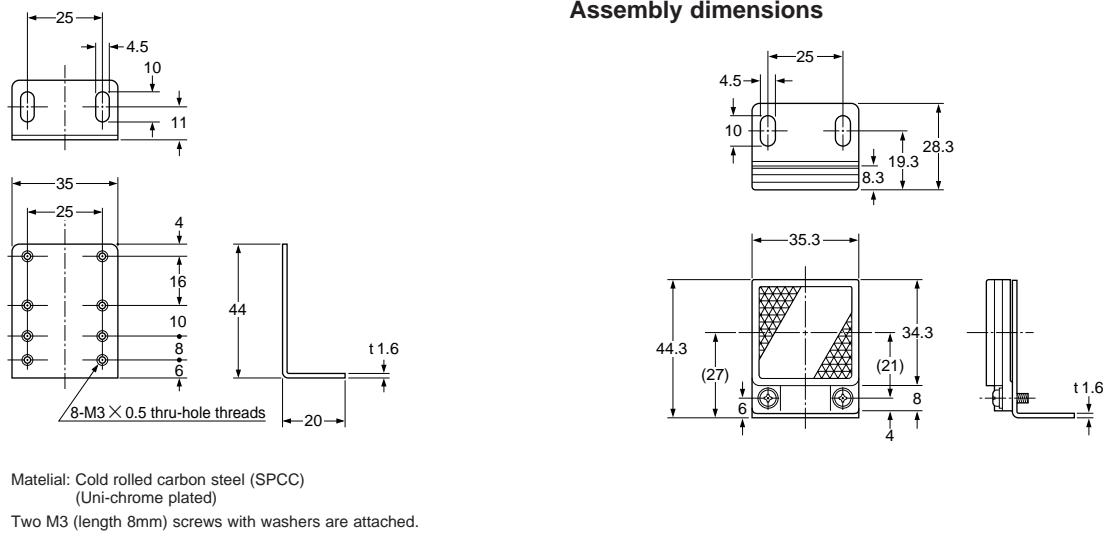

MS-RF23 Reflector mounting bracket for RF-230 (Optional)

Assembly dimensions

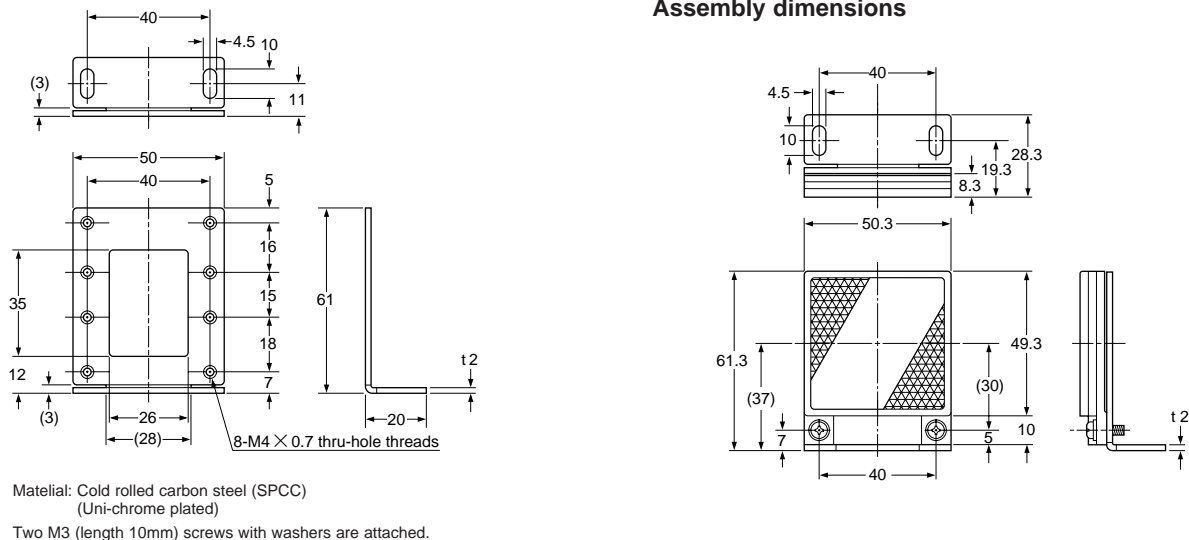

FX-D11/A1/M1

Fiber Sensors

FX-11A

FZ-10

CX-20

Amplifier Built-in Type

CX-30

CX-R/M5/D100/ND300R

EX-10

EX-20