

EX-F70/F60 SERIES

New

Leak Detection Sensor **Amplifier built-in**



High-speed detection even a little liquid leak

* Passed the UL 991 Environment Test



* UL 61010C-1 compatible, Passed the UL 991 Environment Test based on SEMI S2-0200.
 [Category applicable for semiconductor manufacturing: TWW2, Process Equipment]
 [Applicable standards: UL 61010C-1]
 [Additional test / evaluation standards as per intended use: UL991, SEMI S2-0200]

EX-F70 series

Reliable detection

The unique effect of capillarity enables reliable detection of small leaks and viscous liquids.

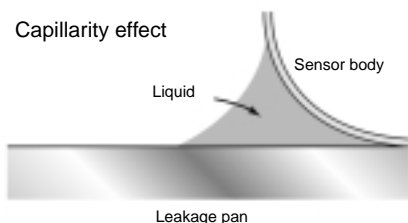

Compact, space-saving

This slim (10 mm 0.394 in) side-mounting sensor is especially good for use in confined spaces.

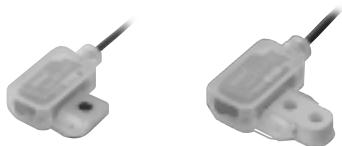
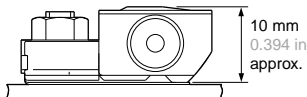

SUS mounting bracket type
EX-F71 □

PVC mounting bracket type
EX-F72 □

Easy operation check

This sensor is equipped with a NORMAL indicator (green) which lights up when mounting correctly, and a FAULT indicator (red) which lights up when sensing the leaked liquid or when mounted incorrectly (forgetting to mount exclusive mounting bracket). So, the operation can be checked easily.

Safe design

- If the sensor is not mounted correctly, if the cable is cut or disconnected, or if the sensor is not operating correctly, the output is the same as when the beam is not received (LEAK).
- Design deals with human errors such as, forgetting to mount, etc.

Easy installation & reset

- Facilitates easy installation: the SUS mounting bracket can be installed using only a single screw and the PVC mounting bracket can be installed using only two screws or an adhesive.
- No component replacement required for resetting after leak detection.
- The simple shape makes it easy to wipe off the leaked liquid.

No need for sensitivity adjustment

No need for sensitivity adjustment with adjuster, so initial mounting is easy.

PVC mounting bracket available **EX-F72** □

A mounting bracket made of PVC (polyvinyl chloride) is available. This type of mounting bracket can be utilized without problems within environments that would corrode normal metal brackets.

New type of detection method

When a leak occurs, the beam from the beam-emitting part scatters through the leaked liquid and is not transmitted to the beam-receiving part.

When leakage occurs

The beam from the beam-emitting part scatters through the leaked liquid and is not transmitted to the beam-receiving part.

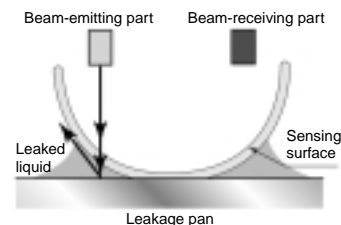

When there is no leakage

The beam from the beam-emitting part reflects off of the surface of the sensor and is transmitted to the beam-receiving part.

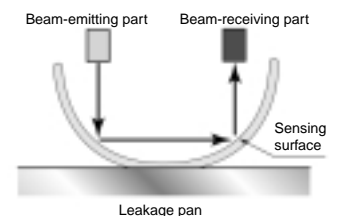

EX-F60 series

PFA enclosure gives excellent chemical resistance

The sensor enclosure and the cable sheath are made from PFA which is highly resistant to chemicals. Accurate sensing can be obtained even if there are leaks of chemicals such as sulfuric acid, hydrochloric acid or ammonia.

Compact, space-saving

Even with its built-in amplifier, the size is compact at 9 mm 0.354 in (D) × 26 mm 1.024 in (W) × 19 mm 0.748 in (H), so that it can be used even in narrow spaces.

Easy installation & reset

The simplified shape makes it easy to clean up after liquid leaks, simply by wiping off the liquid, and no parts need to be replaced.

EX-FC1

Wire-saving unit made especially for connecting leak detection sensors

• Saves wiring! Now connects up to 8 leak detection sensors

EX-FC1 is a simple wire-saving unit for exclusive use with **EX-F71/F72**, **EX-F61/F62** leak detection sensors. **EX-FC1** integrates the outputs from up to 8 leak detection sensors into a single OR output, yielding significant wiring and space savings.

✳️ Even with only one leak detection sensor connected, an OFF signal is output if the sensor detects liquid leakage, or if the unit has been installed incorrectly.

• Slim & compact

Space savings are significant, as the ultra-thin & compact **EX-FC1** has main unit body dimensions of only W20 × H80 × D52 mm W0.787 × H3.150 × D2.047 in.

• Connects easily with one-touch connector

Connections are made by simply inserting the leak detection sensor cable leads into the snap male connector **SL-CP1**, then crimp until the connector snap-locks! This saves the user the time and the trouble of stripping the insulation from each lead before attaching the leads to terminals.



ORDER GUIDE

Leak detection sensors

Type		Appearance	Sensing object	Cable length	Model No.	Output	
General purpose	SUS mounting bracket type		Water, Fluorinert™ (Note 1, 2)	2 m 6.562 ft	EX-F71	NPN open-collector transistor	
				2 m 6.562 ft	EX-F71-PN	PNP open-collector transistor	
	PVC mounting bracket type			2 m 6.562 ft	EX-F72	NPN open-collector transistor	
				2 m 6.562 ft	EX-F72-PN	PNP open-collector transistor	
Chemical-resistant	PFA mounting bracket type		Agent, such as sulfuric acid, Hydrochloric acid, Phosphoric acid or Ammonia etc. (Note 1, 3)	3 m 9.843 ft	EX-F61	NPN open-collector transistor	
				3 m 9.843 ft	EX-F61-PN	PNP open-collector transistor	
	PVC mounting bracket type				3 m 9.843 ft	EX-F62	NPN open-collector transistor
					3 m 9.843 ft	EX-F62-PN	PNP open-collector transistor

Notes: 1) Highly viscous liquid may not be detected stably.

2) Fluorinert™ is the world wide trademark of 3M.

3) The agents mentioned above are examples. Further, PVC mounting bracket may not be used depending on type or viscosity etc. of the agent. For details, please contact our office.

5 m 16.404 ft cable length type

5 m 16.404 ft cable length type (Standard: 2 m 6.562 ft or 3 m 9.843 ft) is also available.

• Table of Model Nos.

Type		Standard type	5 m 16.404 ft cable length type
General use	SUS mounting bracket type	EX-F71	EX-F71-C5
		EX-F71-PN	EX-F71-PN-C5
	PVC mounting bracket type	EX-F72	EX-F72-C5
		EX-F72-PN	EX-F72-PN-C5
Chemical resistant	PFA mounting bracket type	EX-F61	EX-F61-C5
		EX-F61-PN	EX-F61-PN-C5
	PVC mounting bracket type	EX-F62	EX-F62-C5
		EX-F62-PN	EX-F62-PN-C5

Simple wire-saving unit for leak detection sensor

Appearance	Model No.	Output
	EX-FC1	Relay contact 1 a

EX-F70/F60

OPTION

Designation	Model No.	Description
Unit mounting bracket	MS-DIN-3	Mounting bracket for EX-FC1

Unit mounting bracket

- MS-DIN-3

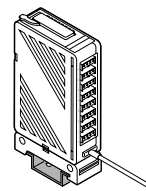

Accessories

- **MS-EX-F7-1** (SUS mounting bracket)
- **MS-EX-F7-2** (PVC mounting bracket)
- **MS-EX-F6-1** (PFA mounting bracket)
- **MS-EX-F6-2** (PVC mounting bracket)
- **SL-CP1** (Snap male connector) 10 pcs. per set
- **SC-PK** (Connector end caps) 8 pcs. per set
- **MS-SL-2** (Unit mounting base)

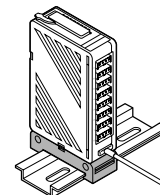
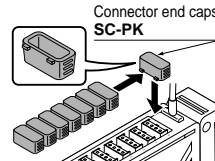
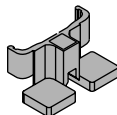
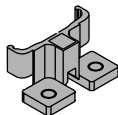
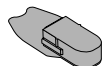

- **MS-EX-F7-3** (PVC mounting bracket)

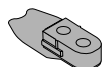

SPECIFICATIONS

Sensors

Item	Model No.	Type	General purpose		Chemical-resistant	
			SUS mounting bracket type	PVC mounting bracket type	PFA mounting bracket type	PVC mounting bracket type
			EX-F71	EX-F72	EX-F61	EX-F62
		NPN output	EX-F71-PN	EX-F72-PN	EX-F61-PN	EX-F62-PN
		PNP output				
Sensing object			Water, Fluorinert™ (Note 1, 2)		Agent, such as Sulfuric acid, Hydrochloric acid, Phosphoric acid or Ammonia etc. (Note 1, 3, 5)	
Supply voltage			12 to 24 V DC ± 10 %		Ripple P-P 10 % or less	
Current consumption			10 mA or less (PNP output type: 15 mA or less)		15 mA or less	
Output			<NPN output type> NPN open-collector transistor <ul style="list-style-type: none"> • Maximum sink current: 50 mA • Applied voltage: 30 V DC or less (between output and 0 V) • Residual voltage: 1.0 V or less (at 50 mA sink current) 0.4 V or less (at 16 mA sink current) 		<PNP output type> PNP open-collector transistor <ul style="list-style-type: none"> • Maximum source current: 50 mA • Applied voltage: 30 V DC or less (between output and + V) • Residual voltage: 1.0 V or less (at 50 mA source current) 0.4 V or less (at 16 mA source current) 	
Utilization category			DC-12 or DC-13			
Output operation			In normal state: ON, When leak detected or the sensor is mounted improperly: OFF			
Short-circuit protection			Incorporated			
Response time			50 ms or less			
FAULT indicator			Red LED (Lights up when the leak liquid is detected, or the sensor is mounted improperly)			
NORMAL indicator			Green LED (Lights up when the sensor is mounted properly)			
Pollution degree			3 (Industrial environment)			
Protection			IP67 (IEC)			
Ambient temperature			- 10 to + 60 °C + 14 to + 140 °F (No dew condensation or icing allowed) Storage: - 20 to + 70 °C - 4 to + 158 °F (Note 4)			
Ambient humidity			35 to 85 % RH, Storage: 35 to 85 % RH			
Ambient illuminance			Incandescent light: 1,000 lx at the light-receiving face			
Emitting element			Infrared LED (non-modulated)			
Material			Enclosure: Polypropylene		Enclosure: PFA	
Cable			0.1 mm ² 3-core PVC cabtyre cable, 2 m 6.562 ft long		0.1 mm ² 3-core PFA cabtyre cable, 3 m 9.843 ft long	
Cable extension			Extension up to total 50 m 164.042 ft is possible with 0.3 mm ² , or more, cable.			
Weight			25 g approx.		60 g approx.	
Accessories			MS-EX-F7-1 (SUS mounting bracket) (Note 6): 1 pc.	MS-EX-F7-2, MS-EX-F7-3 (PVC mounting bracket)(Note 6):1 pc. each for two-point-fixing and adhesive-fixing	MS-EX-F6-1 (PFA mounting bracket): 1 pc.	MS-EX-F6-2 (PVC mounting bracket): 1 pc.

- Notes: 1) Highly viscous liquid may not be detected stably.
 2) Fluorinert™ is the world wide trademark of 3M.
 3) The agents mentioned above are examples. For details, please contact our office.
 4) Liquid being detected should also be kept within the rated ambient temperature range.
 5) PVC mounting bracket may not be used depending on type or viscosity etc. of the agent. For details, please contact our office.

6) The mounting bracket for EX-F71 is not interchangeable with that of EX-F72 due to the different sensitivity settings of each sensor.

SPECIFICATIONS

Simple wire-saving unit

	Designation	Simple wire-saving unit for leak detection sensor
Item	Model No.	EX-FC1
Applicable connector		SL-CP1
Supply voltage		12 to 24 V DC \pm 10 % Ripple P-P 10 % or less
Current consumption		50 mA or less (for the unit itself), 135 mA or less (including the sensor input current when all outputs of sensors are ON)
Output		Relay contact 1a <ul style="list-style-type: none"> • Switching capacity: 30 V 1 A DC (resistive load) • Min. applied load: 10 mV 10 μA DC • Electrical lifetime: 100,000 switching operations or more (rated load, switching frequency 20 operations/min.) • Mechanical lifetime: 50 million switching operations or more (switching frequency 180 operations/min.)
	Utilization category	DC-12 or DC-13
	Output operation	The output relay is ON when the input signal from the sensor is ON
Response time		5 ms or less (excluding the response time of the sensor)
Input No.		8 Nos.
Indicators	Normal	Green LED \times 8 (Light up when the sensor is connected to each channel and the connection setting switch is set to ON)
	Error	Red LED \times 8 (Light up when the leak liquid is detected by a sensor connected to each channel or a sensor is mounted improperly)
	Output	Orange LED [Lights up when the output relay is ON (normal)]
Pollution degree		3 (Industrial environment)
Ambient temperature		- 10 to + 60 $^{\circ}$ C + 14 to + 140 $^{\circ}$ F (No dew condensation or icing allowed), Storage: - 20 to + 70 $^{\circ}$ C - 4 to + 158 $^{\circ}$ F
Ambient humidity		35 to 85 % RH, Storage: 35 to 85 % RH
Material		Enclosure: ABS, Terminal part: PBT, Unit mounting base: POM
Cable		0.2 mm ² 4-core cabtyre cable, 2 m 6.562 ft long
Cable extension		Extension up to total less than 10 m 32.808 ft is possible, with 0.3 mm ² , or more, cable.
Weight		85 g approx.
Accessories		SL-CP1 (Snap male connector): 8 pcs., MS-SL-2 (Unit mounting base): 1 pc.

M-DW1

FD-L43

SH-72

M

HD-T1

EX-F70/F60

FD-F7

FT-F9

FX-301-F

Liquid Leak / Liquid Level Sensing

Glass Substrate / Wafer Sensing

EX-F70/F60

I/O CIRCUIT AND WIRING DIAGRAMS

EX-F7 □ □ NPN output type
EX-F6 □ □

I/O circuit diagram

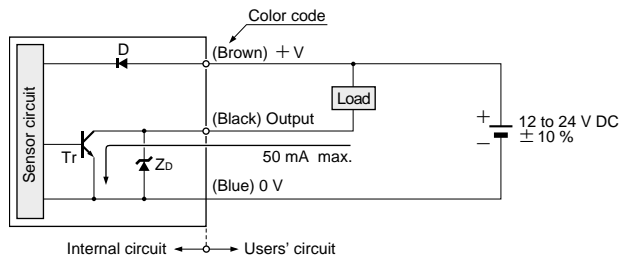

Symbols ... D : Reverse supply polarity protection diode
 Zd: Surge absorption zener diode
 Tr: NPN output transistor

Wiring diagram

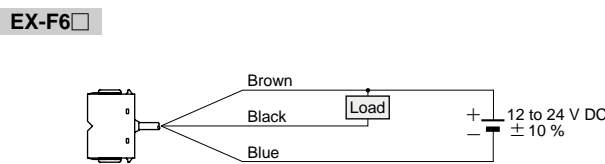
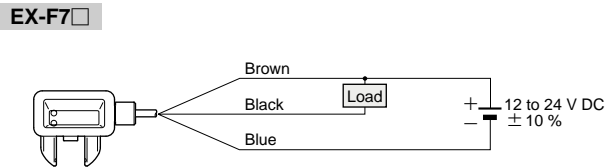

EX-F7 □ □ (-PN) PNP output type
EX-F6 □ □ (-PN)

I/O circuit diagram

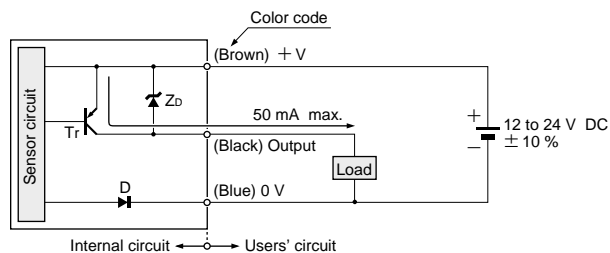

Symbols ... D : Reverse supply polarity protection diode
 Zd: Surge absorption zener diode
 Tr: PNP output transistor

Wiring diagram

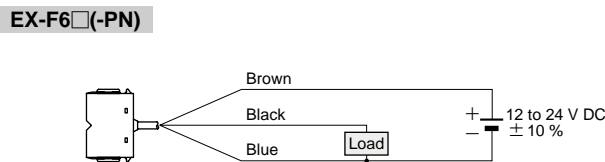
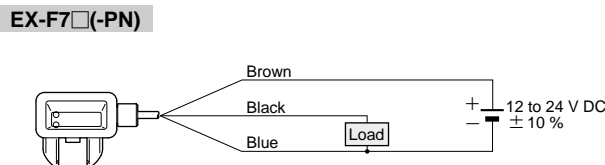

EX-FC1 For one channel

I/O circuit diagram

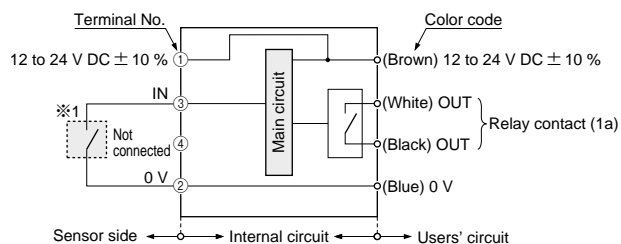

Note: Since the output does not incorporate the short-circuit protection circuit, make sure to use this product within the specification and take care against miss-wiring.

※1
 Non-voltage contact or NPN open-collector transistor
 (Amplifier built-in leak detection sensor)

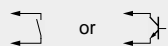

PRECAUTIONS FOR PROPER USE

Refer to p.1135~ for general precautions.



This product is not a safety sensor. Its use is not intended or designed to protect life and prevent body injury or property damage from dangerous parts of machinery. It is a leak detection sensor.

EX-F71□(-PN) EX-F72□(-PN)

Mounting

EX-F71□(-PN)

- Insert the M4 stud-bolt (length 10 mm 0.394 in or more) welded on the user's facilities into the mounting hole of the SUS mounting bracket and screw with an M4 nut (please arrange separately). The tightening torque should be 0.98 N·m or less.

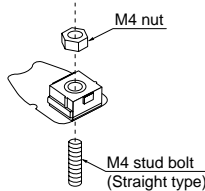

EX-F72□(-PN)

<In case of using the two-point-fixing PVC mounting bracket

- Insert M4 stud-bolts (length 10 mm 0.394 in or more) welded on the user's facilities into the mounting holes of the two-point-fixing mounting bracket and screw with M4 nuts (please arrange separately). The tightening torque should be 0.49 N·m or less.

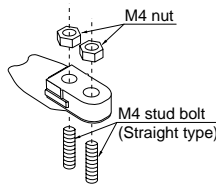

<In case of using the PVC mounting bracket for adhesive fixing>

- Use adhesive to stick fast the mounting bracket on the mounting surface. Please note that if the adhesive sticks out from the bottom surface of the mounting bracket or is 0.5 mm 0.020 in, or more thick, the sensor body cannot be fitted to the mounting bracket.

How to fit the sensor body to the exclusive mounting bracket

- Match the notch in the sensor body with the projection of the exclusive mounting bracket and slide till a click is felt.
- When mounting, make sure to use the brackets included with the unit in order to eliminate human error (such as forgetting to install). If the included brackets are not used, stable sensing is rendered impossible. Also, because sensitivity settings differ between the EX-F71□ and the EX-F72□, their brackets cannot be interchanged.

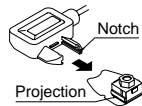

EX-F61□(-PN) EX-F62□(-PN)

Mounting

EX-F61□(-PN)

- Insert the M4 stud-bolt (length 10 mm 0.394 in or more) welded on the user's facilities into the mounting hole of the PFA mounting bracket and screw with an M4 nut (please arrange separately). The tightening torque should be 0.98 N·m or less.

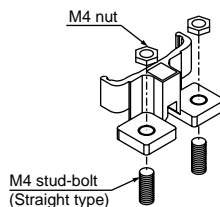

EX-F62□(-PN)

- Please note that if the excess adhesive from the bottom surface of the exclusive mounting bracket is remained, the sensing capability may be affected.
- Use adhesive for vinyl chloride (PVC).

How to fit the sensor body to the exclusive mounting bracket

- Align the projections in the sensor body with the notches of the exclusive mounting bracket and slide till a click is felt.

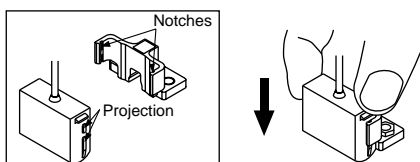

How to remove the sensor body from the exclusive mounting bracket

- Pinch the projections of the sensor body and pull the body upwards. Never pull the cable, since it may cause a cable break.

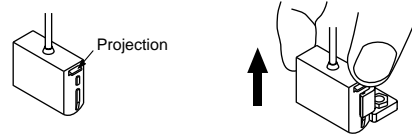

EX-FC1

Mounting

- When the unit is mounted, be sure to use the unit mounting base **MS-SL-2** (accessory). When the unit mounting base is installed to the unit, insert the base aligned with the groove of the unit and move until the unit stopper is locked.

- ① Insert aligned with the groove
- ② Make the unit stopper locked.

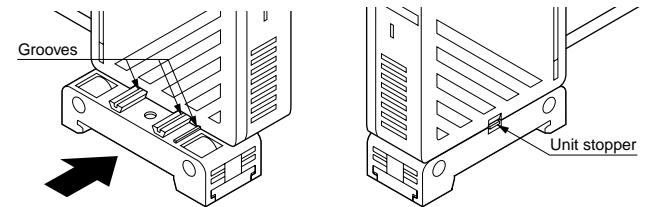

- Two installation positions are available for the unit mounting base so that the unit direction can be changed. Install the base at one of them.

Mounting position 1

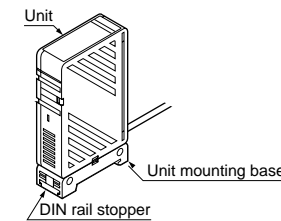

Mounting position 2

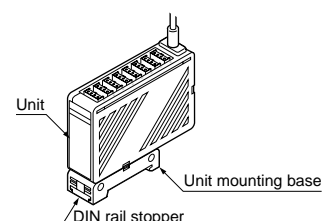

<In case a DIN rail or the mounting bracket **MS-DIN-3** (optional) is used.

- ① Fit the rear part of the unit mounting base on a 35 mm 1.378 in width DIN rail or the mounting bracket **MS-DIN-3** (optional).
- ② Press down the front part of the unit mounting base on the 35 mm 1.378 in width DIN rail and fit the front part of the base on the DIN rail.

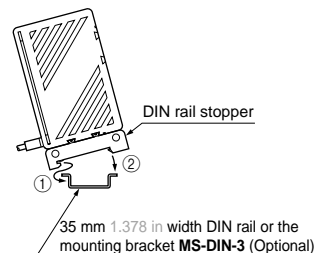

- ※For removal, insert a flat-bladed screwdriver into the DIN rail stopper and pull towards yourself.

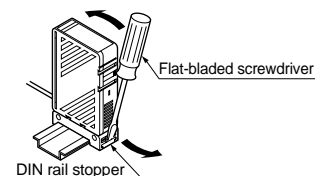

<In case of using screws>

- Mount using M4 pan head screws with a tightening torque of 0.8 N·m or less. However, in case of side mounting, make sure to mount the unit such that the unit stopper faces front.

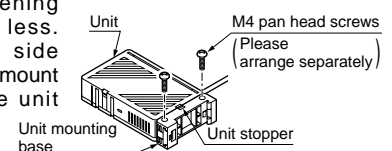

EX-F70/F60

PRECAUTIONS FOR PROPER USE

Refer to p.1135~ for general precautions.

EX-FC1

Functional description

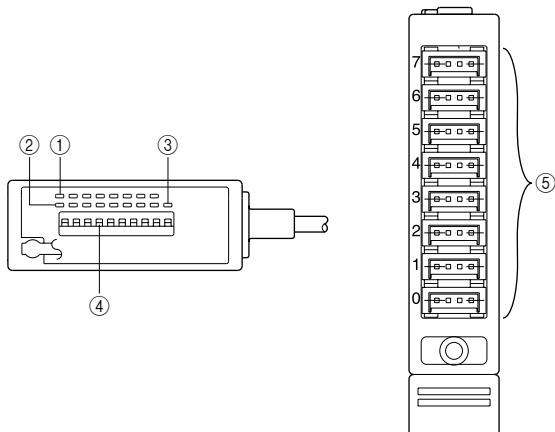

	Description	Function
①	Normal indicator (Green LED × 8)	Lights up when sensors are connected to each channel and the connection setting switch is set to ON.
②	Error indicator (Red LED × 8)	Lights up when the leak liquid is detected by any sensor connected or any sensor is mounted improperly. (For details, refer to 'Connection setting switch'.)
③	Output indicator (Orange LED)	Lights up when the output relay is ON (Normal).
④	Connection setting switch	Set the switch to ON when the leak detection sensor is connected, set to OFF when the leak detection sensor is not connected.
⑤	Connector	Connect the leak detection sensors.

Connection

- Make sure that the power supply is off while connecting or disconnecting the snap male connector **SL-CP1**.
- Take care that wrong wiring will damage the product.
- The terminal No. ④ of the snap male connector **SL-CP1** is not used. Take care not to connect to the terminal No. ④ by mistake. Further, if there are unused wires, please insulate them.

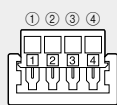

	Content
①	+ V
②	0 V
③	IN
④	Not connected

- For details of the hook-up method of the snap male connector **SL-CP1**, refer to the instruction manual enclosed with **SL-CP1**.

Connection method

- ① By holding **SL-CP1** with the cable connected, insert it into the connector of **EX-FC1** reliably till it stops.

Disconnection method

- ② By holding **SL-CP1**, pull it from **EX-FC1** horizontally.

Note: Do not pull out by holding the cable, as this can result in cable disconnection.

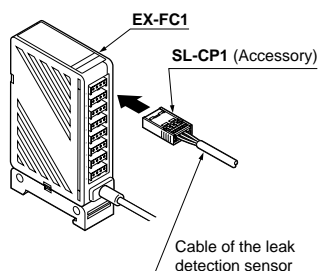

Connection setting switch

- The connection setting should be carried out in the power supply off condition after removing any electrostatic charge which may be present on your body.

Operation matrix for each indicator

Operation	Connection state of the leak detection sensor	State of connection setting switch	Leak detected condition	Normal indicator (green)	Error indicator (red)	Output indicator (orange)
Normal	Connected	ON	No leak	ON	OFF	ON
		OFF	Leak	OFF	ON	OFF
Error	Unconnected	OFF	—	OFF	OFF	ON
		ON	—	OFF	OFF	OFF

- For the channel that the unit sensor is connected to and the connection setting switch is set to 'ON' side, the error indicator (red) lights up for a moment when the power is turned on. This is not a malfunction for the unit because it is caused by characteristic of the sensor.
- Make sure to set the connection setting switch with the connector No. to which the leak detection sensor is connected, to 'ON' side.
- In case both the normal indicator (green) and the error indicator (red) light up, the connection setting switch with the connector No. to which the leak detection sensor is connected, is not set to 'ON' side. Set the connection setting switch with the connector No. to which the leak detection sensor is connected, to 'ON' side.
- In case the error indicator (red) lights up, the leak detection sensor detects leak or the connection setting switch is set to 'ON' side without connecting the leak detection sensor. If the connection setting switch is set to 'ON' side without connecting the leak detection sensor, set the connection setting switch to 'OFF' side.
- If the leak detection sensor detects leak or the connection setting switch is set to 'OFF' side in the state that the leak detection sensor is improperly mounted to the mounting bracket, the sensor judges as the output is ON. Be careful when setting.

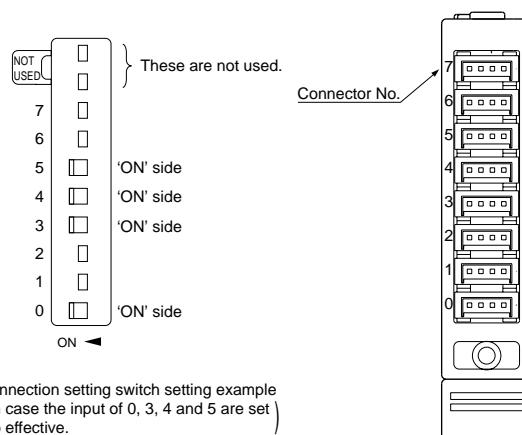

PRECAUTIONS FOR PROPER USE

Refer to [p.1135](#)~ for general precautions.

Common cautionary items

Wiring

- Make sure that the power supply is off while wiring.
- Verify that the supply voltage variation is within the rating. Take care that if a voltage exceeding the rated range is applied, or if an AC power supply is directly connected, the sensor may get burnt or damaged.
- If power is supplied from a commercial switching regulator, ensure that the frame ground (F.G.) terminal of the power supply is connected to an actual ground.
- In case noise generating equipment (switching regulator, inverter motor etc.) is used in the vicinity of this product, connect the frame ground (F.G.) terminal of the equipment to an actual ground.
- Do not run the wires together with high-voltage lines or power lines or put them in the same raceway. This can cause malfunction due to induction.
- Make sure to use an isolation transformer for the DC power supply. If an auto-transformer (single winding transformer) is used, this product or the power supply may get damaged.
- In case a surge is generated in the used power supply, connect a surge absorber to the supply and absorb the surge.
- Cable extension is possible up to total 50 m 164.042 ft (**EX-FC1**: less than 10 m 32.808 ft) with 0.3 mm², or more, cable. However, in order to reduce noise, make the wiring as short as possible.
- Take care that stress is not directly applied to the cable joint or the connector.
- **EX-FC1** is since the output does not incorporate a short-circuit protection circuit, make sure to use this product within the specification and take care against wrong wiring.

Others

- Avoid using the product in an explosive atmosphere because this product does not have an explosive-proof protective construction.
- In case air bubbles are drawn into the sensing part, take care that it may take some time for sensing to stabilize, or sensing may even become unstable.
- When conducting maintenance after operation, wipe all liquid from the fiber head and mounting bracket with a soft cloth. If there is liquid remained or scratch on the sensing surface or the exclusive mounting bracket, normal operation cannot be performed.
- Do not use during the initial transient time (Leak detection sensor: 30 sec. approx., **EX-FC1**: 0.5 sec. approx.) after the power supply is switched on.
- Since this sensor employs non-modulated infrared LED, take sufficient care against extraneous light. Do not expose the sensing part directly to the extraneous light.
- Avoid dust, dirt, and steam. Further, do not use this product in an environment containing organic solvents.
- Take care that **EX-F7**□ and **EX-FC1** does not come in direct contact with oil, grease or organic solvents, such as, thinner, etc.
- In case this sensor is used where electrostatic charge is present, use a metal leak pan, which should be connected to an actual ground.
- This sensor is suitable for indoor use only.

Glass Substrate / Wafer Sensing		M-DW1
M		FD-L43
SH-72		
HD-T1		
Liquid Leak / Liquid Level Sensing		EX-F70/F60
FD-F7		
FT-F9		
FX-301-F		

EX-F70/F60

DIMENSIONS (Unit: mm in) The CAD data in the dimensions can be downloaded from SUNX website: <http://www.SUNX.co.jp/>

**EX-F71(-PN)
EX-F72(-PN)** Sensor

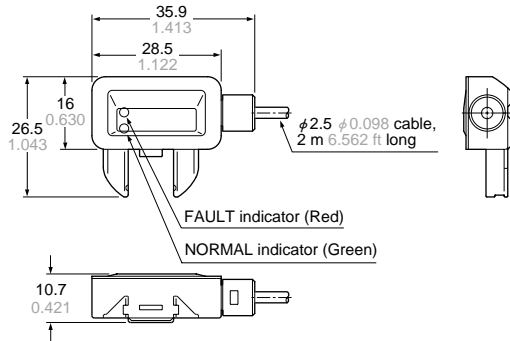

Assembly dimensions EX-F71(-PN) with SUS mounting bracket

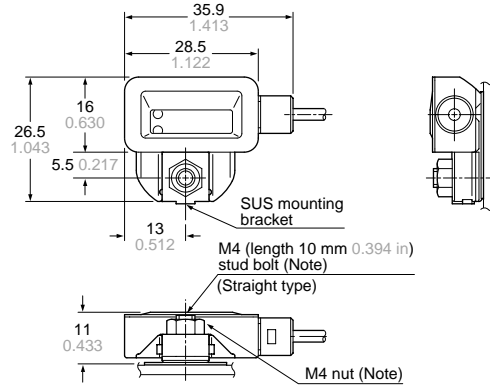

Note: A M4 stud bolt has been welded to this unit.
M4 nut is not supplied with the sensor.
Please arrange it separately.

Assembly dimensions EX-F72(-PN) with PVC mounting bracket

Two-point-fixing

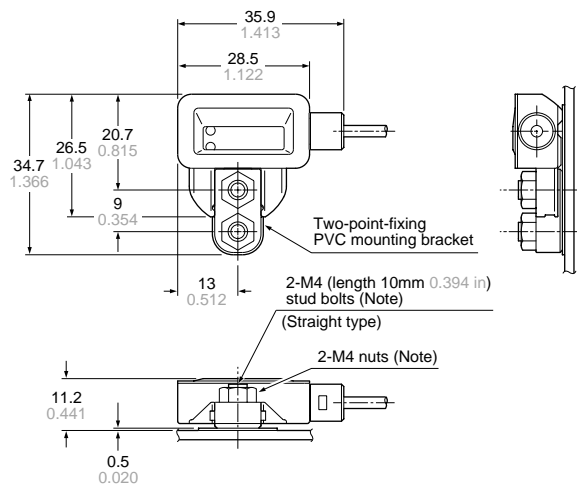

Adhesive fixing

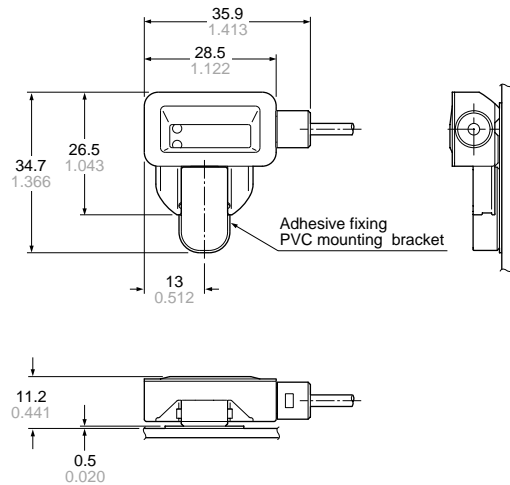

Note: M4 stud bolts have been welded to this unit.
M4 nuts are not supplied with the sensor.
Please arrange it separately.

DIMENSIONS (Unit: mm in) The CAD data in the dimensions can be downloaded from SUNX website: <http://www.SUNX.co.jp/>

**EX-F61(-PN)
EX-F62(-PN)** Sensor

Assembly dimensions EX-F61(-PN) with PFA mounting bracket

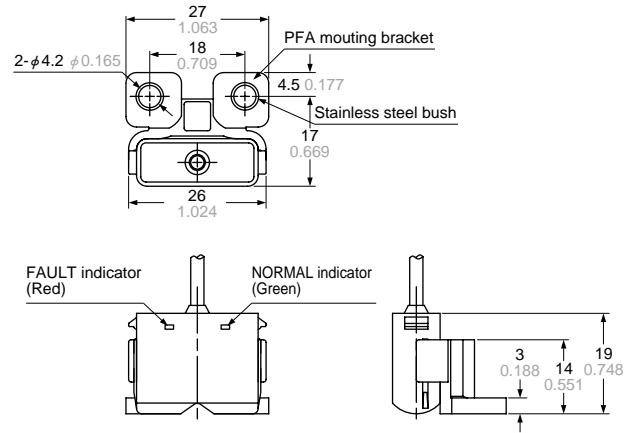
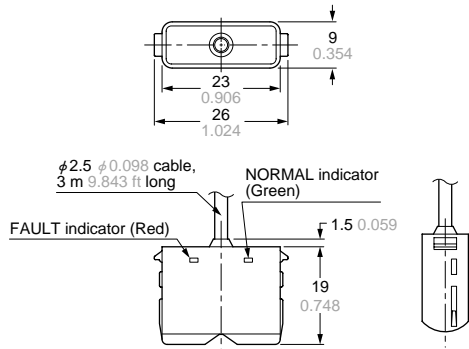

Assembly dimensions EX-F62(-PN) with PVC mounting bracket

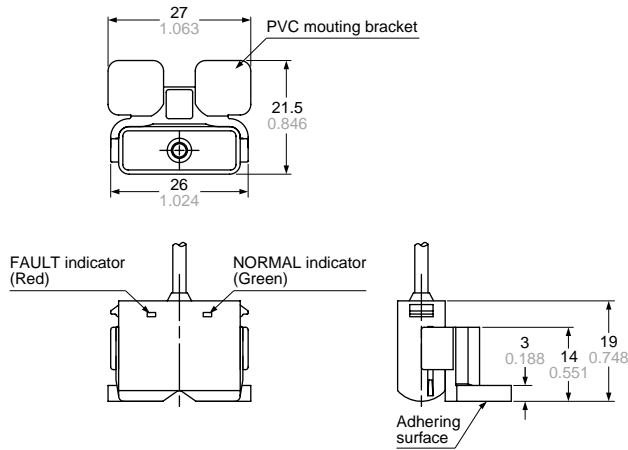

EX-FC1 Simple wire-saving unit for leak detection sensor

MS-DIN-3 Amplifier mounting brackets (Optional)

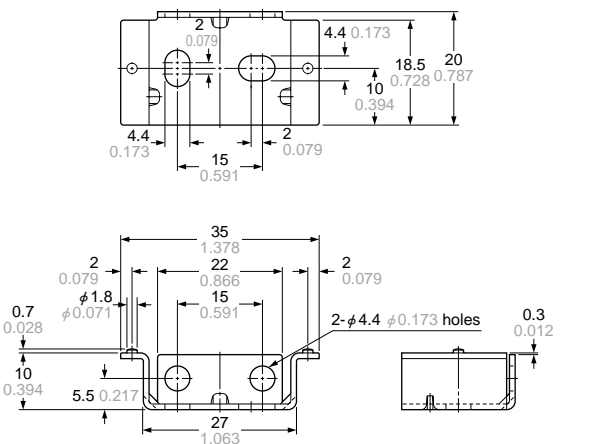
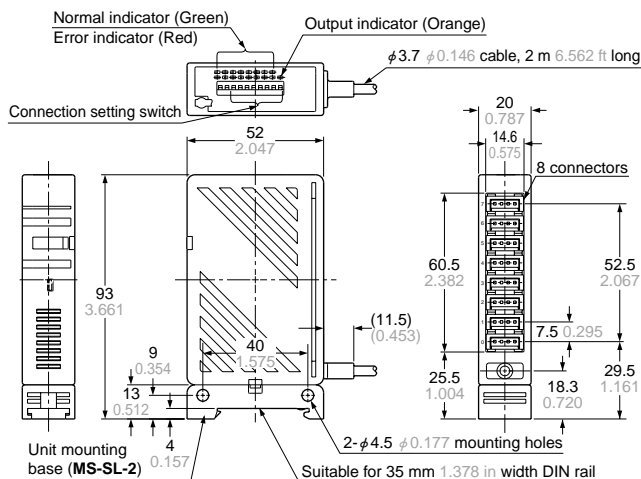

M-DW1

Glass Substrate / Wafer Sensing

FD-L43

SH-72

M

HD-T1

EX-F70/F60

Liquid Leak / Liquid Level Sensing

FD-F7

FT-F9

FX-301-F